

ANTENNAS | HELI-8 SERIES

CIRCULAR POLARISED, BI-DIRECTIONAL MINE/TUNNEL ANTENNA

Wi-Fi; 2400 – 2500 MHz, 14.5 dBic

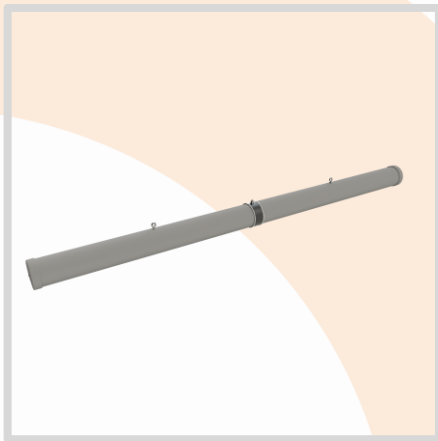

 2400 – 2500 MHz	 14.5 dBic	 Increase X Mb/s	 Bi-Directional	 2.4 – 2.5 GHz	 Machine to Machine
 IP 65	 -40°C to 80°C	 Chemical Protection	 Fire Resistant		

- Circular Polarised HELI antenna provides enhanced signal propagation and connection stability within a tunnel
- Circularly polarised
- Bi-directional – radiates in both directions in a tunnel
- Careful mechanical design provides ruggedness, water and dust resistance (IP 65)
- Ideal for Mining & Tunnel M2M and IoT deployments



Mining



Tunnelling



Mining and Surface



Urban

APPLICATION AREAS

Product Overview

The HELI-8 is a high gain, directional antenna, which complements our Wi-Fi MinePoynt tunnel and mine antennas. The combination of MinePoynt beam antennas for long distance thru-tunnel links with this directional antenna, exploits Poynting's fifteen years' experience in designing and manufacturing antennas for underground mining data networks. This antenna is also suitable for oil/gas chemical environments where IS equipment is required. The HELI 8 tunnel antenna is the ideal antenna for 2.4 - 2.5 GHz wireless applications in tunnels. In tests, both the data rate and range achieved with this antenna was greater than obtained when using linearly polarized panel antennas of the same gain. The hardy construction of this antenna makes it ideal for the mining environment. HELI-8 is a bi-directional antenna whilst the closely related HELI-3 fires in one direction. This antenna gives you a low-cost network infrastructure for current voice and data needs in mines and tunnels.

Features

- Bi-directional antenna
- Proven antenna performance giving maximum range
- Improved performance due to circularly polarised
- Ideal for mining and tunnelling applications
- High gain over the 2400 MHz Wi-Fi band
-

Application Areas

- Supplementing fibre/cable networks by providing wireless "Hotspots" to areas to enhance mobility or extend networks to inaccessible areas such as mines and tunnels
- Underground telemetry
- Creation of complete in tunnel/mine wide data networks and or internet connectivity
- Seamless connection to personnel using VOIP phones, smart devices and tablets





Frequency Bands

The Heli-8 is a Wi-Fi / ISM antenna that works from | 2400 – 2500 MHz |

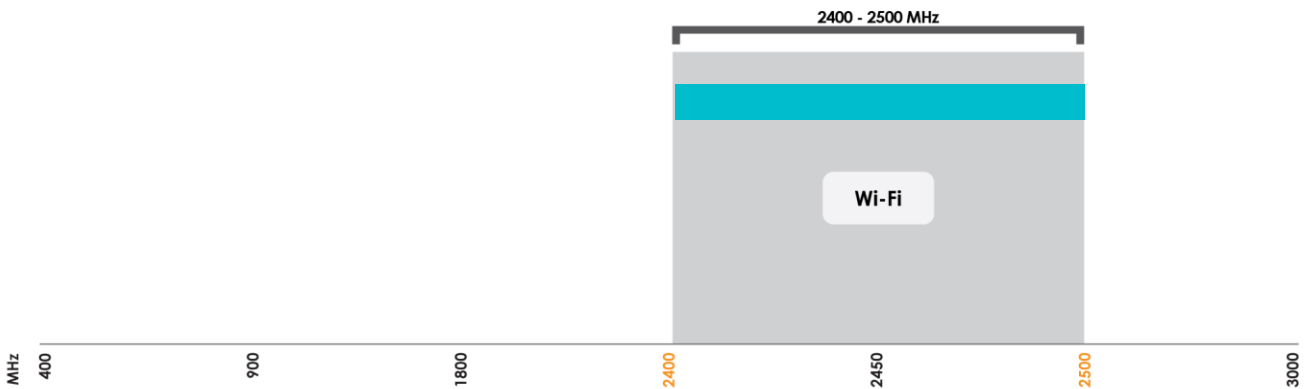

Indicates the Wi-Fi bands on which Heli-8 works

Antenna Overview

	
Ports	1
SISO / MIMO	SISO
Frequency Bands	2400 – 2500 MHz
Peak Gain	14.5 dBic
Coax Cable Type	N/A
Coax Cable Length	N/A
Connector Type	N-Type (F)

**The connector is factory mounted to the antenna*

Electrical Specifications

Frequency Bands:	2400 – 2500 MHz
Gain (Max):	14.5 dBic
VSWR:	<1.5:1
Feed Power Handling:	30 W
Input Impedance:	50 Ohm (nominal)
Polarisation:	Left-Hand Circular Polarised
DC Short:	N/A

Product Box Contents

Antenna:	A-HELI-0008
Mounting Bracket:	Two 6mm eyebolts for ceiling mount

Ordering Information

Commercial name:	HELI-8
Order product code:	A-HELI-0008
EAN number:	6009710920350

Mechanical Specifications

Product Dimensions:	2004 mm x 116 mm x 142 mm
Packaged Dimensions:	2200 mm x 180 mm x 180 mm
Weight:	5.1 kg
Packaged Weight:	6.02 kg
Radome Material:	PVC
Radome Colour:	429C RAL 7038
Mounting Type:	Ceiling mount

Environmental Specifications, Certification & Approvals

Wind Survival:	<120 km/h
Temperature Range (Operating):	-40°C to +80°C
Environmental Conditions:	Outdoor/Indoor
Water Ingress Protection Ratio/Standard:	IP 65
Salt Spray:	MIL-STD 810G/ASTM B117
Operating Relative Humidity:	Up to 98%
Storage Humidity:	5% to 95% - non-condensing
Storage Temperature:	-40°C to +80°C
Enclosure Flammability Rating:	UL 94-HB
Impact Resistance:	IK 08
Product Safety & Environmental:	Complies with CE and RoHS standards



Antenna Performance Plots

VSWR

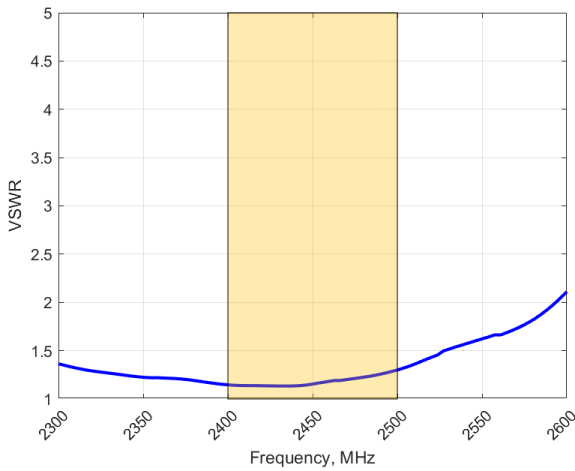

GAIN (EXCLUDING CABLE LOSS)

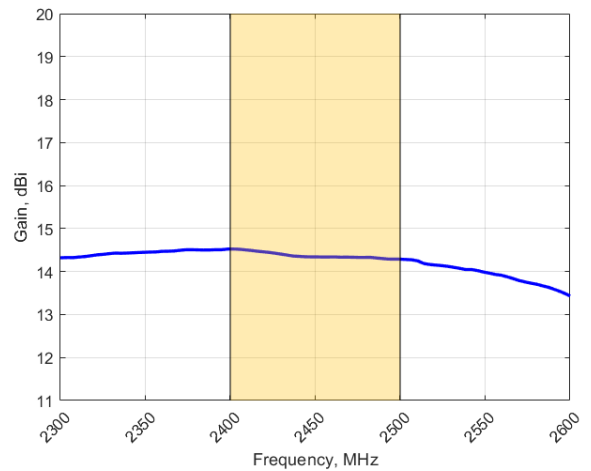

Voltage Standing Wave Ratio (VSWR)*

VSWR is a measure of how efficiently radio-frequency power is transmitted from a power source, through a transmission line, into a load. In an ideal system, 100% of the energy is transmitted which corresponds to a VSWR of 1:1.

The HELI-8 delivers superior performance across all bands with a VSWR of <1.5:1.

*VSWR measured without a cable

Gain* in dBic

14.5 dBic is the peak gain across all bands from 2400 – 2500 MHz

*Antenna gain measured with circular polarised standard antenna

Radiation Patterns

Azimuth & Elevation: 2400 – 2500 MHz

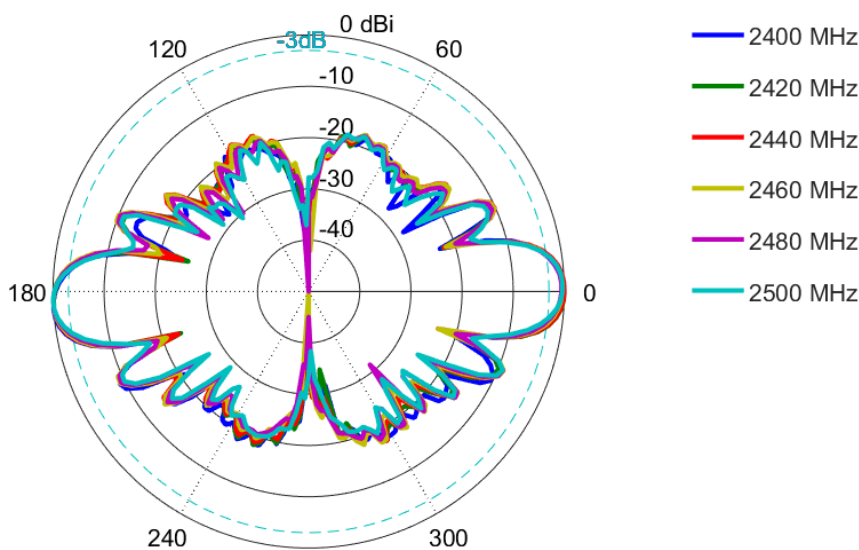

Technical Drawings

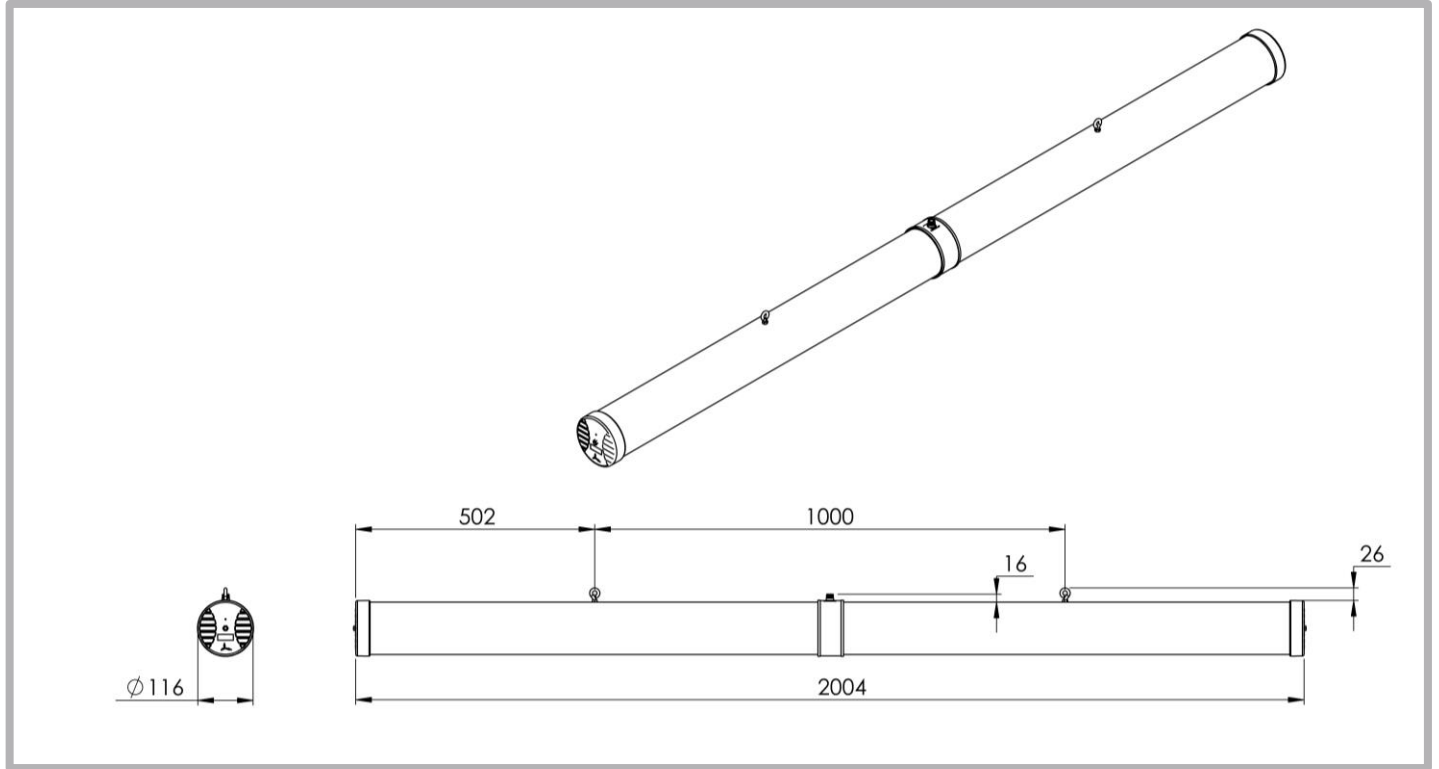

Additional Accessories

Extension Cables: Up to 15m HDF 195

See accessories technical specifications on www.poynting.tech

CONTACT POYNTING

Poynting Antennas (Pty) Ltd - Head Office

Unit 4, N1 Industrial Park,
Landmarks Avenue,
Samrand, 0157, South Africa

Phone: +27 (0) 12 657 0050

E-mail: info@poynting.tech

International Email: sales-global@poynting.tech

Poynting Europe

Regus Business Center Neue Messe Riem
Kronstadter Straße 4
81677 München
Germany

Phone: +49 89 7453 9002

E-mail: sales-europe@poynting.tech

Poynting USA

1804 Owen Court, Suite 104,
Mansfield,
TX 76063
USA

Phone: +1 817 533-8130

E-mail: sales-us@poynting.tech